

EMT50HDP

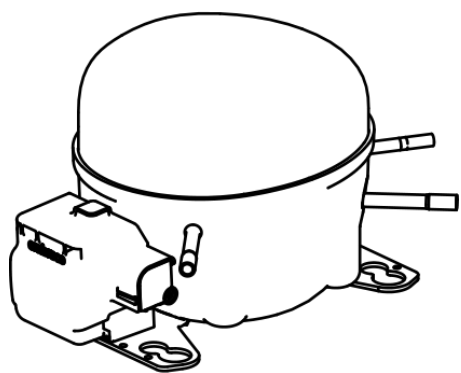

ENGINEERING CODE
194MA67

REFRIGERANT
R-134a

POWER SUPPLY
220-240 V 50 Hz

APPLICATION
HBP

MOTOR TYPE
RSIR

STANDARD
EN12900

COOLING CAPACITY
421 W

EFFICIENCY
2.5 W/W

DATA

GENERAL DATA

Model	EMT50HDP
Type	Hermetic Reciprocating
Technology	ON/OFF
Compressor Application	HBP
Expansion Device	Capillary Tube
Compressor Cooling	Static/220
Starting Torque	LST
Plant	ITALY

ELECTRICAL DATA

Start Winding Resistance	33.6 Ω at 25°C
Run Winding Resistance	18.7 Ω at 25°C
Locked Rotor Amperage (LRA) 50Hz	6.4 A

MECHANICAL DATA

Displacement	4.5 cm ³
Oil Charge	180 ml
Oil Type	ESTER
Oil Viscosity	ISO22
Weight	7.7 Kg

ELECTRICAL COMPONENTS

CSR CSIR BOX	No
Starting Device Type	PTC
Starting Device Description	V230
Overload Protection	T0521/26

PERFORMANCE

TESTED CONDITIONS

Tested Refrigerant	R-134a
Tested Application	HBP
Tested Standard	EN12900
Tested Cooling	Static
Tested Voltage	220 V
Max Refrigerant Charge	250 g
Refrigerant Temperature	Dew

RATED POINTS

Condensing Temperature °C	Evaporating Temperature °C	Cooling Capacity W	Efficiency W/W	Power Consumption W	Current A	Gas Flow Rate kg/h
50	5	421	2.5	169	-	10.55

Test Condition: Subcooling 0 K, Return Gas 20 °C. Data are an indication of performance based simulation.

PERFORMANCE CURVE

Condensing Temperature 35°C

Evaporating Temperature °C	Cooling Capacity W	Efficiency W/W	Power Consumption W	Current A	Gas Flow Rate kg/h
-15	218	2.17	101	-	4.62
-10	279	2.53	110	-	5.93
-5	350	2.91	120	-	7.48
0	432	3.34	129	-	9.28
5	523	3.87	135	-	11.34
10	625	4.54	138	-	13.67

Test Condition: Subcooling 0 K, Return Gas 20 °C. Data are an indication of performance based simulation.

PERFORMANCE CURVE

Condensing Temperature 45°C

Evaporating Temperature °C	Cooling Capacity W	Efficiency W/W	Power Consumption W	Current A	Gas Flow Rate kg/h
-15	185	1.69	110	-	4.30
-10	238	1.97	121	-	5.55
-5	300	2.24	134	-	7.05
0	373	2.53	147	-	8.80
5	455	2.84	160	-	10.83
10	546	3.20	170	-	13.14

Test Condition: Subcooling 0 K, Return Gas 20 °C. Data are an indication of performance based simulation.

PERFORMANCE CURVE

Condensing Temperature 55°C

Evaporating Temperature °C	Cooling Capacity W	Efficiency W/W	Power Consumption W	Current A	Gas Flow Rate kg/h
-10	201	1.57	128	-	5.20
-5	254	1.79	142	-	6.62
0	316	2.00	158	-	8.30
5	387	2.22	175	-	10.27
10	467	2.44	191	-	12.53

Test Condition: Subcooling 0 K, Return Gas 20 °C. Data are an indication of performance based simulation.

ENVELOPE



External

EXTERNAL CHARACTERISTICS

Base Plate		SMALL	
Tray Holder		YES	
Connector	Internal Diameter	Shape	Material
Suction	6.1 mm	SLANTED 42°	COPPER
Discharge	4.86 mm	STRAIGHT	COPPER
Process	6.1 mm	SLANTED 42°	COPPER

EXTERNAL DIMENSIONS

SHELL

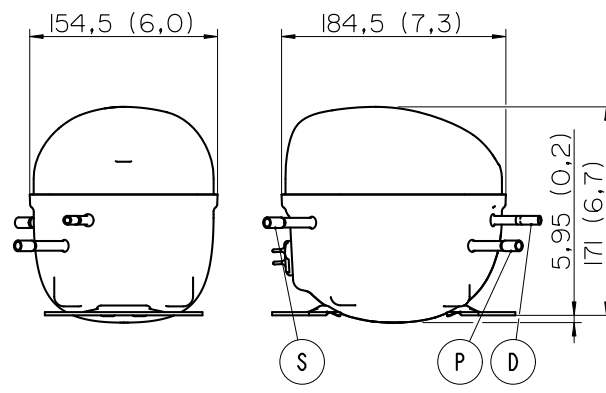

BASE

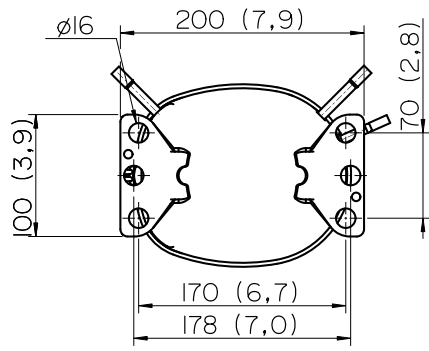

FENCE

