



Tecumseh

Verflüssigungssatz
Spannungscode : TZ

TAJN2464ZBR-TZ

Gewerbliche Kühlung (Tiefk.) (BP)

400V 3~ 50Hz / 440V 3~ 60 Hz

R452A / R404A

TAJN2464ZBR-TZ

Bedingungen	Frequenz	Nennkälteleistung		Schalleistung ISO3745 / ISO 3743-1
		Watts	BTU/h	
EN13215 / R452A	50 Hz	764	2604	65 dBA
EN13215 / R404A	50 Hz	848	2892	65 dBA

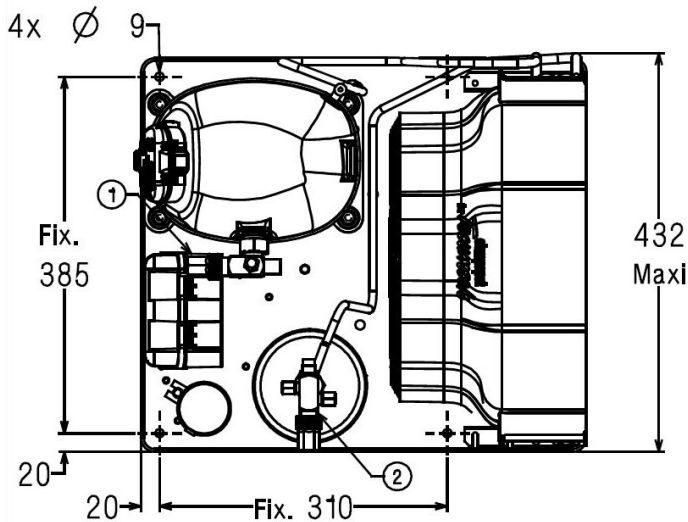
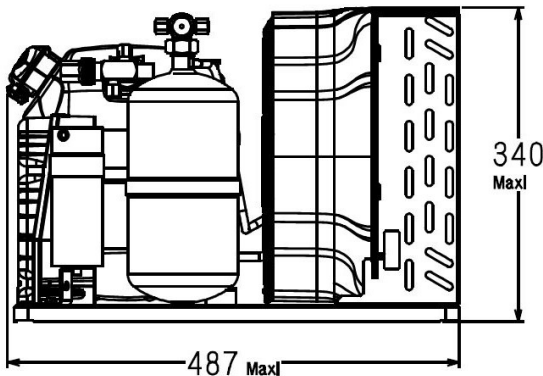

* EN13215 : T°Verf. 32.0°C / T°Verdampf.. -35.0°C / T°Sauggastemp.. 20.0°C
T°Unterkühlung. 3.0K

Nettogewicht (kg)	34.0
Expansion	Expansionsventil
Luftdurchsatz (m³/h)	900 / 900
Datenblatt Verdichter	124SU-TZ
Typ Schaltanlage	TRI
LRA	
Nennstrom	2.4 2.3
Maximalstrom	4 4.2
Anlaufstrom	16.1 16.5
FAN_RPM	
1200 / 1200	
Mechanische Leistung (W)	30.0
Durchmesser (mm)	300
Schutz	Schutz
Schutzart (IP)	IP54
Verflüssiger	M300/3900
Receiver_Cap	
Volumen (l)	2.35
MWP (bar)	32.0
Suction_Type	
Komponente	Vanne Orientable
Außendurchmesser	15.9 (5/8")
Anschlussstyp	zum Löten
Liquid_Line_Type	
Komponente	Vanne Orientable
Außendurchmesser	9.5 (3/8")
Anschlussstyp	zum Löten
ID Kundenanschluss	VR
Gitter	maille < à 8mm

NB: Tecumseh behält sich das Recht vor, die in diesem Dokument enthaltenen Informationen ohne vorherige Ankündigung zu verändern



Tecumseh

TAJN2464ZBR-TZ	Tension TZ : 400V 3~ 50Hz / 440V 3~ 60 Hz
-----------------------	--

Les performances sont données dans les conditions EN13215 :	Gaz aspirés :	20.0 °C
Condition Dew	Sous refroidissement :	3.0 K
The performance data are in EN13215 conditions :	Return gas :	20.0 °C
Dew Condition	Subcooling :	3.0 K

50 Hz R452A										
N°6024										
5 T ambience	6 T évaporation	(°C)	-45	-40	-35	-30	-25	-20	-15	-10
25	1 P frigorifique	(Watt)	474	661	880	1130	1408	1710	2033	2371
	2 P absorbée	(W)	524	633	750	880	1024	1188	1374	1586
	3 I absorbée	(A)	1.61	1.70	1.82	1.98	2.17	2.41	2.67	2.98
	4 Tc	(°C)	27.1	28.9	31.1	33.6	36.4	39.4	42.7	46.2
32	1 P frigorifique	(Watt)	383	560	764	993	1247	1521	1812	2118
	2 P absorbée	(W)	496	618	747	887	1042	1215	1411	1632
	3 I absorbée	(A)	1.56	1.67	1.82	1.99	2.20	2.45	2.72	3.04
	4 Tc	(°C)	33.5	35.1	37.1	39.4	42.0	44.9	48.0	51.4
43	1 P frigorifique	(Watt)		403	581	779	994	1227	1474	1737
	2 P absorbée	(W)		574	724	884	1057	1248	1460	1697
	3 I absorbée	(A)		1.62	1.79	2.00	2.23	2.49	2.79	3.11
	4 Tc	(°C)		45.1	46.7	48.6	50.9	53.5	56.4	59.5

50 Hz R404A										
N°5054										
5 T ambience	6 T évaporation	(°C)	-45	-40	-35	-30	-25	-20	-15	-10
25	1 P frigorifique	(Watt)	545	742	973	1234	1519	1823	2137	2455
	2 P absorbée	(W)	560	679	806	943	1094	1262	1452	1667
	3 I absorbée	(A)	1.70	1.81	1.95	2.11	2.31	2.55	2.82	3.13
	4 Tc	(°C)	29.3	31.4	33.8	36.3	39.1	42.1	45.3	48.8
32	1 P frigorifique	(Watt)	451	636	848	1085	1342	1615	1895	2175
	2 P absorbée	(W)	542	671	808	955	1116	1294	1494	1720
	3 I absorbée	(A)	1.68	1.80	1.95	2.13	2.35	2.59	2.88	3.20
	4 Tc	(°C)	35.6	37.5	39.7	42.1	44.7	47.6	50.7	54.0
43	1 P frigorifique	(Watt)		470	653	854	1068	1291	1518	1745
	2 P absorbée	(W)		640	794	959	1138	1335	1554	1798
	3 I absorbée	(A)		1.77	1.95	2.15	2.39	2.65	2.96	3.29
	4 Tc	(°C)		47.1	49.0	51.2	53.6	56.2	59.0	62.1

1 = cooling capacity 2 = power input 3 = current 4 = condensing temperature 5 = ambient temperature 6 = evaporating temperature

Nota : Tecumseh se réserve le droit de modifier les informations contenues dans ce document sans préavis.

Note : Tecumseh reserves the right to change information contained in this document without notification.

© 2018 Tecumseh Products Company
All rights reserved