

Compresseur / Compressor
Code tension / Voltage code : T

TFH4522Z

Froid commercial et industriel positif (HP)
Commercial & industrial application (HBP)

400-440V / 50-60Hz - 3~

R404A



N° 226CU-T - ind f

Conditions Conditions	fréquence frequency	Prod frigorifique nominale / nominal refrigerating capacity			Puis. sonore Sound level
		Watts	Kcal/h	BTU/h	
EN12900*	50 Hz	4629	3981	15785	ISO 3745 / ISO 3743-1
EN12900*	60 Hz	5454	4690	18598	
Cecomaf	50 Hz	4390			72 dBA
Cecomaf	60 Hz	5191			

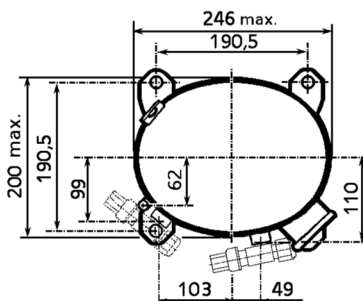
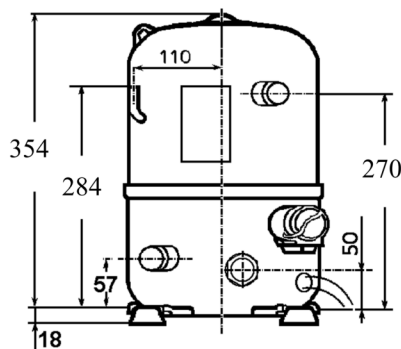

Cylindrée / Displacement : 39.9 cm³
Poids net / Net weight : 30 Kg
Charge en huile / Oil charge : 1480 cm³
Type d'huile / Oil type : P.O.E /
Détente / Expansion device : Capillaire/Détendeur
 Capillaire/Exp° valve
Refroidissement / Cooling : Ventilé / Forced

Résistance à 20° C / Windings resistances at 20° C
 Phases 1,2,3. / Phase Nr 1,2,3 : 6.3 Ohms

Intensité / Current
 nom. / Rated current RLA : 3.9 / 4.1 A
 max. / Max current : 5.4 / 5.9 A
 dém. / Start current LRA : 24 / 26 A

Ap. Electrique / Electrical equipment : TRI

Protecteur / Overload: Interne / Internal

* EN12900: T°cond.+50°C / T°évap. +5°C/ T°gas aspirés. +20°C / Sous refroidissement. 0K

* EN 12900 : Cond. T° +50°C / Evap. T° +5°C / Return gas T° +20°C / Subcooling. 0K

Pour conduites Ø ext / For tubing O.D.

Aspiration Suction	Refoulement Discharge	Charge Process
15.9 (5/8")	12.7 (1/2")	6.35 (1/4")

Les caractéristiques données dans cette fiche technique peuvent évoluer sans avis préalable, avec les améliorations que 'TECUMSEH EUROPE' entend toujours apporter à sa production.
 'TECUMSEH EUROPE', in a constant endeavour to improve its products reserves the right to change any information contained in this leaflet without prior warning.



L'UNITE
HERMETIQUE



Tecumseh

TFH4522Z	Tension T : 400V 3~ 50Hz / 440V 3~ 60 Hz	R404A	N°226CU-T	Ind f
-----------------	---	--------------	------------------	--------------

Les performances sont données dans les **conditions EN 12900** :
Elles sont certifiées uniquement en 50 Hz

Gaz aspirés : 20°C
Sous refroidissement : 0°K

The performance data are in **EN 12900 conditions** :
They are only certified in 50 Hz

Return gas : 20°C
Subcooling : 0°K

50 Hz R404A

4 T condensation	5 T évaporation	(°C)	-25	-20	-15	-10	-5	0	5	10	15
30	1 P frigorifique	(W)	1555	2147	2849	3677	4644	5767	7062	8542	10224
	2 P absorbée	(W)	1013	1167	1301	1418	1524	1623	1719	1816	1919
	3 I absorbée	(A)	2.75	2.91	3.06	3.19	3.31	3.41	3.5	3.57	3.62
40	1 P frigorifique	(W)		1636	2261	2983	3817	4778	5882	7144	8579
	2 P absorbée	(W)		1173	1356	1516	1659	1787	1907	2022	2136
	3 I absorbée	(A)		2.93	3.14	3.33	3.51	3.67	3.82	3.95	4.06
50	1 P frigorifique	(W)			1636	2243	2934	3724	4629	5663	6842
	2 P absorbée	(W)			1338	1554	1746	1917	2074	2219	2357
	3 I absorbée	(A)			3.11	3.36	3.6	3.83	4.03	4.23	4.4
60	1 P frigorifique	(W)				1494	2033	2643	3339	4136	5051
	2 P absorbée	(W)				1505	1759	1987	2193	2381	2557
	3 I absorbée	(A)				3.3	3.6	3.89	4.15	4.41	4.64

60 Hz R404A

4 T condensation	5 T évaporation	(°C)	-25	-20	-15	-10	-5	0	5	10	15
30	1 P frigorifique	(W)	1786	2555	3438	4450	5606	6923	8415	10097	11985
	2 P absorbée	(W)	1143	1376	1569	1737	1889	2039	2199	2380	2594
	3 I absorbée	(A)	2.5	2.72	2.93	3.11	3.29	3.45	3.59	3.73	3.84
40	1 P frigorifique	(W)		1863	2661	3553	4552	5676	6938	8354	9939
	2 P absorbée	(W)		1320	1590	1817	2013	2192	2363	2541	2737
	3 I absorbée	(A)		2.65	2.92	3.18	3.42	3.65	3.86	4.06	4.24
50	1 P frigorifique	(W)			1859	2635	3482	4417	5454	6609	7897
	2 P absorbée	(W)			1513	1822	2085	2314	2520	2717	2916
	3 I absorbée	(A)			2.84	3.17	3.48	3.77	4.06	4.32	4.58
60	1 P frigorifique	(W)				1707	2407	3158	3974	4873	5867
	2 P absorbée	(W)				1726	2077	2378	2642	2879	3104
	3 I absorbée	(A)				3.08	3.46	3.83	4.18	4.51	4.83

1 = refrigerating capacity 2 = watt input 3 = current 4 = condensing temperature 5 = evaporating temperature

Nota : Les caractéristiques données dans cette fiche technique peuvent évoluer sans avis préalable, avec les améliorations que "TECUMSEH EUROPE" entend toujours apporter à sa production.

Note : "TECUMSEH EUROPE", in a constant endeavour to improve its products reserves the right to change any information contained in this leaflet without prior warning.